

© 1958 BY AMP INCORPORATED. ALL RIGHTS RESERVED. AMP PRODUCTS COVERED BY PATENTS AND/OR PATENTS PENDING.

REVISIONS

LTR	DESCRIPTION	DATE	APPROVED
B	REDRAWN, & ADDED TAPE NO. P-6080 ^{WM}	4-29-70	<i>[Signature]</i>
C	REV PER G-4732	JT 7/27/88	<i>[Signature]</i>
D	REV/0720-0036-93	TQ 3-5-93	<i>[Signature]</i>
E	REV PER OG3A-0274-01	26/01/01	<i>[Signature]</i>

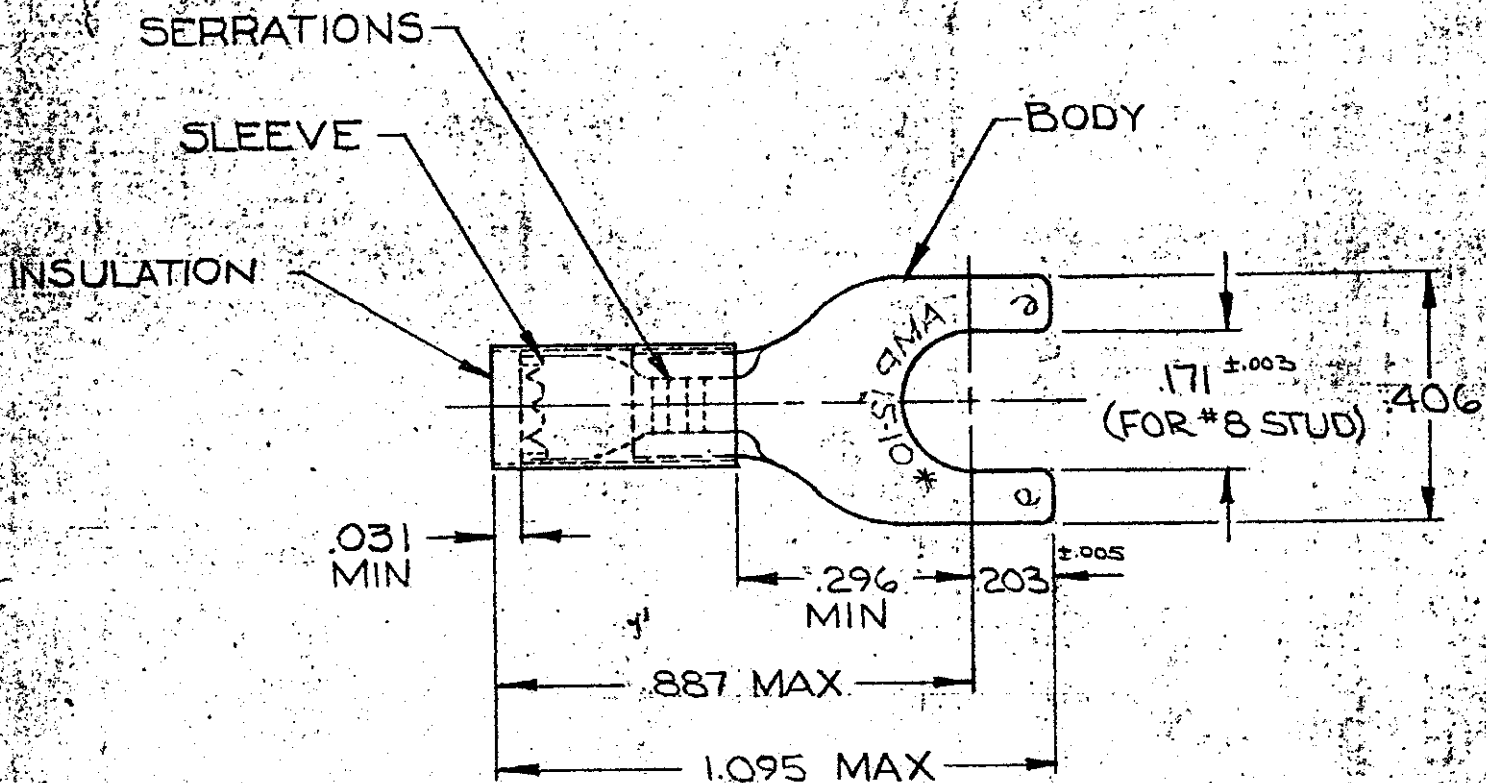

25	LOOSE PC, BAG	8-35152-5	△
4	LOOSE PC, BLS	8-35152-4	△
50	LOOSE PC, BOX	8-35152-2	
1	35152 ON TAPE	2-35152-1	BODY: COPPER (QQ-C-576) TIN PL (MIL-T-10727)
1	WIRE TERMINAL	35152	SLEEVE: COPPER (QQ-C-576) INSULATION: NYLON COLOR: YELLOW
QTY	DESCRIPTION	PART NO	MATERIAL & FINISH

UNLESS OTHERWISE SPECIFIED DIMENSIONS ARE IN INCHES TOLERANCES ON: DECIMALS ±.008 ANGLES ±5°	CONTRACT NO.	AMP AMP INCORPORATED HARRISBURG, PENNSYLVANIA		
	DR. <i>Wayne Millhous</i> 4-28-70			
	CHK <i>J.M. Ensminger</i> 4-29-70	NAME	WIRE TERMINAL	
	APPD <i>L. Walsh</i> 4-29-70	P.I.D.G. SPADE	WIRE SIZE: 12-10	
MATERIAL	REL. <i>J.M. Ensminger</i> 4-30-70	SIZE	CODE IDENT NO.	NUMBER
SEE TABLE	DSGN APPD	A	00779	35152
	OTHER APPD	SCALE	NTS	SHEET 1 OF 1

CUSTOMER DRAWING